



GLASS FRONT MERCHANDISER



A10107

Covers Models:

- 3129 -- HR 32
- 3130 -- GF23 II
Horizon II
- 3140 -- Outdoor
Series

Parts Manual

Table of Contents

GENERAL INFORMATION	1
Minimum Order:	1
Payment:	1
To Order by Mail:	1
To Order by Fax	2
To Order by Phone.....	2
Returns	2
Limitation of Liability	2
Key.....	3
Commodity Codes.....	3
FINAL ASSEMBLY	4
DOOR ASSEMBLY	6
Coin Insert Assembly	8
Delivery Assembly.....	10
Light Assembly.....	12
POWER PANEL ASSEMBLY	13
TRAY CONFIGURATIONS	14
TRAY ASSEMBLY – 3- AND 4-WIDE	16
CABINET ASSEMBLY	18
OUTDOOR SECURITY PACKAGE	20

GENERAL INFORMATION

You may order parts from your distributor or from VendNet™. If you have any questions when placing your order, please call and we'll be happy to assist you. Please provide the following information when placing your order:

- Quantity Required
- Part Number
- Description of part

NOTE

When "Right" and "Left" are used with a part name, it is taken to mean that the person is facing the machine with the door closed.

- Vendor Model Number
- Vendor Serial Number
- Shipping and Billing Address
- Preferred Method of Shipment
- Customer Account Number

Minimum Order:

You may wish to inquire on prices of parts and minimum order amount at the time of your order. If you order less than the minimum, please check our catalog for other parts you may require to bring your order up to the minimum amount.

VendNet™ reserves the right to change these requirements without notice.

Payment:

OPEN ACCOUNT with approved credit. MASTER CARD – VISA – DISCOVER – C.O.D.

To Order by Mail:

You may mail your order for replacement parts by providing the necessary information as requested above to:

VendNet™
165 North 10th Street
Waukee, Iowa 50263-0488 - USA

Order forms are available upon request or you may use your own purchase order form.

To Order by Fax

You may Fax your order for replacement parts by providing the necessary information as requested above to: VendNet™.
1-515-987-4447

To Order by Phone

You may call in your order for replacement parts by providing the necessary information as requested above to VendNet™ Parts Department.

USA 1-800-833-4411

Canada 1-800-858-4730

Other locations 1-515-274-3641

Returns

RESTOCKING CHARGE 20%. A restocking charge of 20% will apply to merchandise accepted by VendNet™ for return, except items processed as warranty.

All items returned must be accompanied by a Return Form clearly stating the reason for return. Returns are to be shipped freight prepaid to VendNet™, 165 North 10th Street, Waukee, Iowa 50263-0488. (Return Forms are available upon request from VendNet™.)

Limitation of Liability

VendNet™ shall not be liable for any injury, loss or damage, whether direct, incidental or consequential arising out of the use of or the inability to use any part, parts or products sold by VendNet™. The remedies of the buyer set forth herein are exclusive, and the liability of VendNet™. With respect to any contract or sale or anything done in connection herewith, whether in contract, in tort, under any warranty, or otherwise, shall not, except as expressly provided herein, exceed the price of the part, parts or products on which such liability is based. Any statements or representations about the parts or product, other than those contained herein, do not constitute warranties and shall not be relied on by the buyer and shall have no force of effect unless contained in a written agreement signed by officers of VendNet™.

If you have any questions, check out our Website

<http://www.vendnetusa.com>

or please call VendNet™.

Ask for the Parts Department.

We will be happy to assist you.

E-Mail: vendnet@vendnetusa.com

Key

ADHV	Adhesive
AP	Attaching Part
CC.....	Commodity Code
ETW.....	External Tooth Lock Washer
HWH	Hex Washer Head
MS	Machine Screw
PH.....	Pan Head
TH	Truss Head
VAC	Volt – Alternating Current
VDC	Volt – Direct Current
W/	With
W/O.....	Without

Commodity Codes

AS	Assembly	RA	Rails
BU	Bushing	RC.....	Refrigeration Component
CB	Control Board	RE	Relay
CL.....	Clip	RI.....	Rivet
CO.....	Compressor	RU	Rubber
CP	Clamp	SC	Fastener
EL.....	Electrical Component	SF.....	Sign Face
FA.....	Fan	SL.....	Slide
FU	Fuse, Breaker	SM.....	Screw-Machine
GA	Gasket	SP	Spring, Auger
GR.....	Grommet	ST.....	Stamping, Bracket
HA	Harness	SW	Switch
HI.....	Hinge	TA.....	Tape
IN.....	Insulation	TC	Temperature Control, Thermostat
LA.....	Label, Tag	TU	Tubing
LE.....	Leg, Leveler	WA	Washer
LO	Lock	WD	Wood
LP.....	Lamp	WE	Welded Assembly
MA.....	Manual	WT	Wire Tie
NU	Nut	XF.....	Transformer, Ballast
PI.....	Pin		
PL.....	Plastics		

FINAL ASSEMBLY

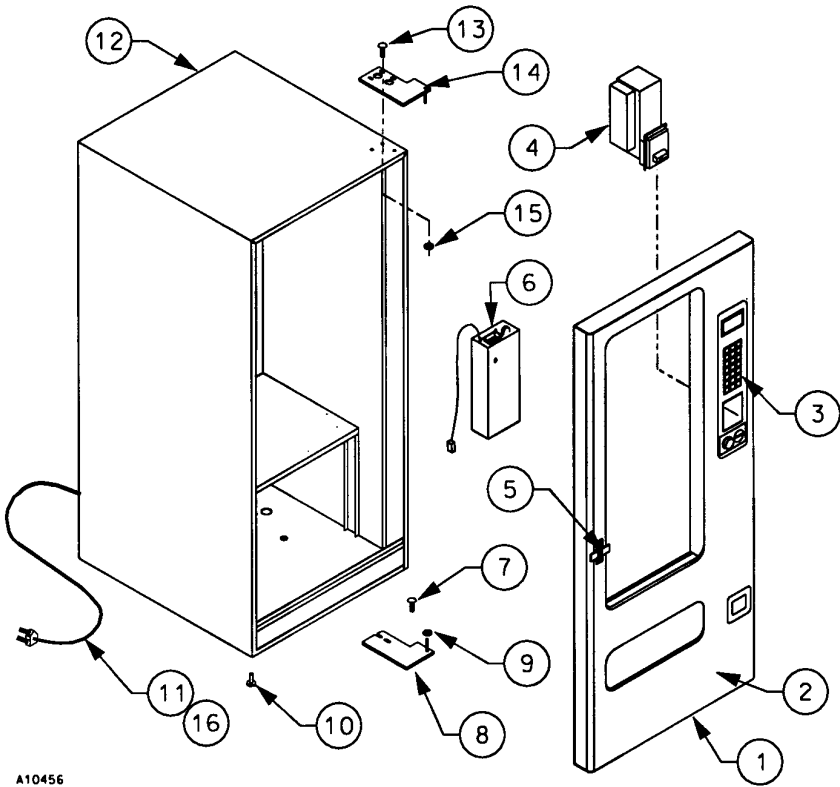

A10456

Final Assembly

ITEM	PART NO.	DESCRIPTION	QTY	CC
1	1214664-003	Door Assembly – Page 6 – 3W	1	AS
	1214664	Door Assembly – Page 6 – 4W	1	AS
2	1214834	Door Assembly – Page 6 – Outdoor	1	AS
	4206458	Door Decal – Horizon (Black)	1	LA
	4206458-001	Door Decal – Horizon (Silver)	1	LA
	4208213	Door Decal – Detail Center	1	LA
	4209018-001	Door Decal - Sports Center	1	LA
	4209019	Door Decal – Yellow Bar Tackle	1	LA
3	4209178	Door Keypad Decal	1	LA
4	4205536-124	Validator – MDB – BA32SA	1	CM
5	4060330	Lock Cyl w/2 Keys (Specify Key Series)	1	LO
6	4200419-GX	Coin Mechanism – MDB	1	CM
7	8801388	5/16-18 x 3/4 HWH Type D	3	SC
8	1212060-005	Hinge Stake – Bottom	1	RA
9	4050767	3/8 Nylon Flat Washer	1	WA
10	4060310	Leg Leveler	4	LE
11	4203520	Power Cord W/Plug	1	HA
12	1214663-003	Cabinet Assembly – Page 16 – 3W	1	AS
	1214663	Cabinet Assembly – Page 16 – 4W	1	AS
	1214835	Cabinet Assembly – Page 16 – Sport	1	AS
13	4050099	5/16-18x3/4 Carriage Bolt	3	SC
14	1212060-006	Hinge Stake – Top	1	RA
15	8810015	5/16-18 Flange Lock Nut	3	NU
16	8620494	Tag, Plug - Warning	1	LA
		Service Package 1214490-003 (Not Shown)	1	AS
	4208808-002	Service Manual	1	MA
	4206816	Safety Manual	1	MA
	4206451	Bulletin – Scroll Lock	1	LA
	4203793-001	Dollar Label \$1 - option	1	LA
	4203793-002	Dollar Label \$2 - option	1	LA
	4203793-003	Dollar Label \$3 - option	1	LA
	4203793-004	Dollar Label \$4 - option	1	LA
	4203793-005	Dollar Label \$5 - option	1	LA
	4025748	Product Ejector	10	PL
Not Shown	4200032-000	Label – Made in USA	1	LA
	1214547	4-in Leg Kit (Option)	1	AK
	1214704-002	Leg Assembly	4	AS
	4201385	5/16 x 18 x 1 Tread Roller	16	SC
	4205593	Leg Spacer	4	ST
	8363374	Leg Leveler	4	LE

DOOR ASSEMBLY

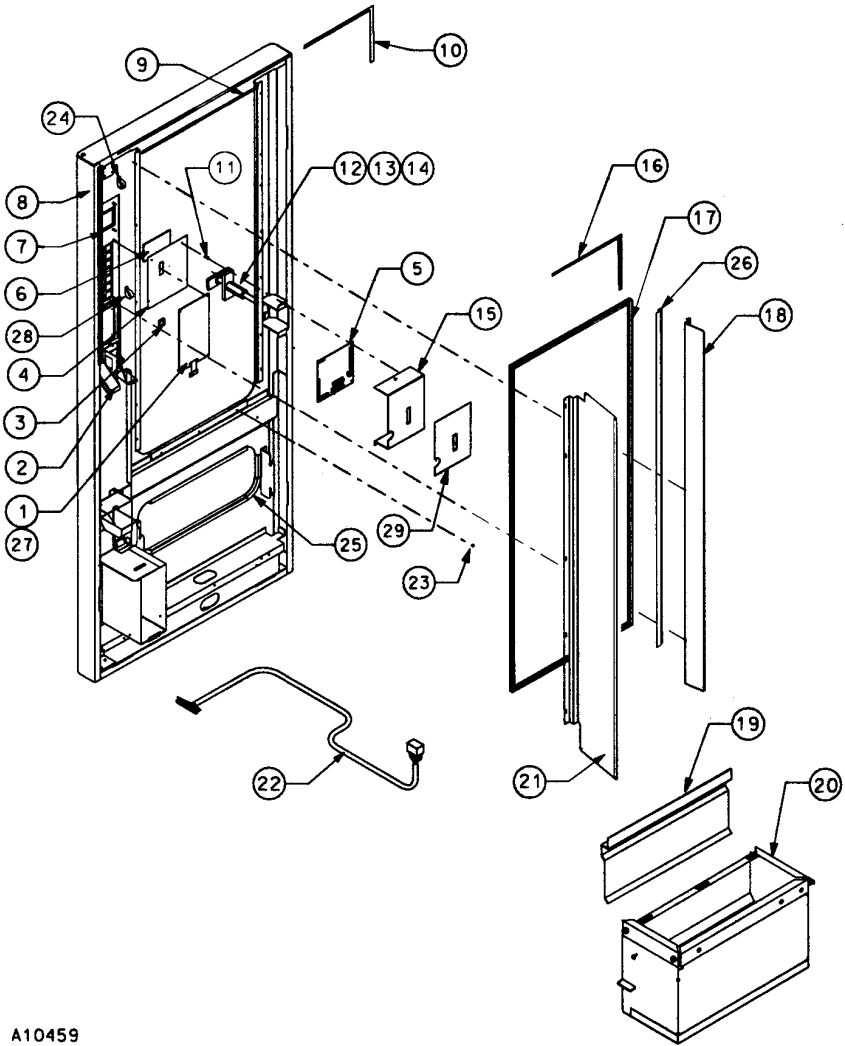

A10459

Door Assembly

ITEM	PART NUMBER	DESCRIPTION	QTY	CC
1	1214532	Keypad Assembly	1	AS
	4201202	Keypad #909190-1	1	KP
	4208735	Keypad Mount	1	ST
2		Coin Insert Assembly – Page 8	1	
3	4025741	Push Button	21	PL
4	4208737	Board Mount	1	ST
5	4208201-001	F-80 Controller 5/16	1	CB
6	4202841-008	Readout Window	1	PL
7	4060006-500	1/4 X 1/2-in. Foam Tape	5.5'	TA
8	1214488-003	Door Weldment – 3W	1	WE
	1214488-004	Door Weldment – 4W	1	WE
	1214836	Door Weldment – Outdoor	1	WE
9	1214550-003	Light Assembly – 3W (Page 12)	1	AS
	1214550-004	Light Assembly – 4W (Page 12)	1	AS
10	4202255	Gasket 1/4x3/4 W/ADHV – 3W	10.25 ft	GA
	4202255	Gasket 1/4x3/4 W/ADHV – 4W	11.25 ft	GA
11	4206879	Board Standoff-3/8"	4	PL
12	4203486	1/4 Turn Handle, Black	1	LO
13	4050338	10-32x1/2 Phil FH Ms	2	SC
14	4050495	10-32 Nut, Two Way Lock	2	NU
15	4208784	Board Cover	1	ST
16	4209025-006	Glass Gasket - 3W	1	GA
	4209025-007	Glass Gasket - 4W	1	GA
17	4203478-006	Display Window 42-in - 3W	1	GL
	4203478-007	Display Window 42-in - 4W	1	GL
18	4203485-002	Door Partition – Left	1	ST
19	4203484-007	Bottom Door Deflector - 3W	1	ST
	4203484-008	Bottom Door Deflector - 4W	1	ST
20	1212040-006	Delivery Assembly - Pg 10 - 3W	1	AS
	1212040-009	Delivery Assembly – Pg 10 – 4W	1	AS
21	4207441-001	Anti-Theft – Right	1	ST
22	4208804	Door Harness	1	HA
23	4050423	8-18x1/4 Phil HWH Screw	A/R	SC
24	4060134	Plastic Wire Clamp 1-in.	1	CP
25	4203263	1/4" x 1/2 Foam Tape	8	TA
26	4203566-003	Window Retainer	2	ST
27	4203696	Ribbon Cable Clamp	1	CP
28	8370959-3	3/4" Clamp	2	CP
29	4208789	Service Mode Label	1	LA

DOOR ASSEMBLY (continued)

Coin Insert Assembly

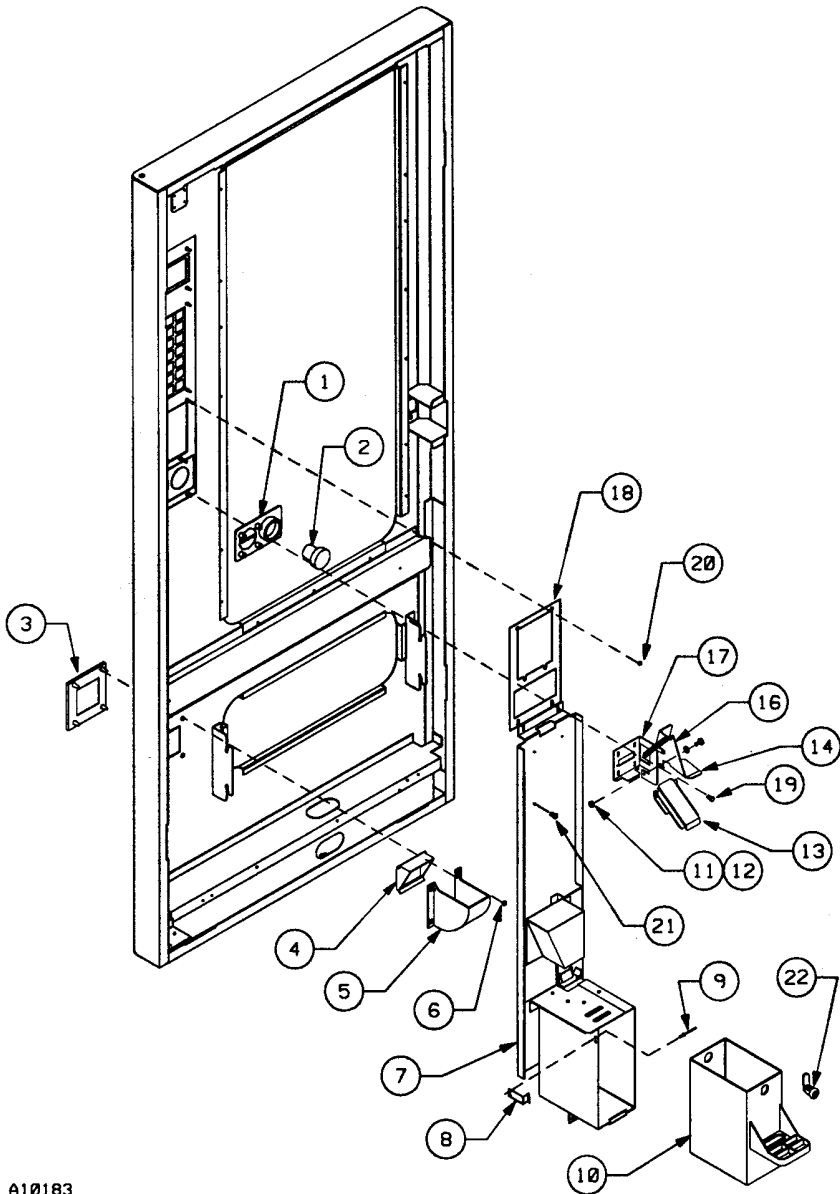

A10183

Coin Insert Assembly

ITEM	PART NUMBER	DESCRIPTION	QTY	CC
1	4203186-004	Coin Insert Black 1 1/8	1	PL
2	4203187	Coin Return Button	1	PL
3	4203209	Coin Cup Bezel	1	PL
4	4203208	Coin Cup Door	1	PL
5	4203207	Coin Cup	1	PL
6	4050747	1/4 Stamped Hex Nut	4	NU
7	1214833	Mechanism Mount	1	WE
8	4210216	Latch	1	St
9	4050667	1/8x1/4 Alum Pop Rivet	2	RI
10	4208890	Coin Box - Plastic	1	PL
11	4050511	8-32 Nut-Two Way Lock	1	NU
12	4030100	Bushing-Spacer	1	BU
13	1212097-001	Coin Chute	1	WE
14	4208726	Coin Return Lever	1	ST
15	4050240	8-32x3/8 Phil PH MS	1	SC
16	4021020	Spring 9/32 X 1 3/32	1	SP
17	4208727	Coin Chute Mount	1	ST
18	4208734	Coin Insert Mount	1	ST
19	4201942	6-20x3/16 Phil PH Type-B	2	SC
20	8800956	8-32 Hex Nut W/ETW	14	NU
21	4050423	8-18x3/8 Phil PH Type-AB	16	SC
22	4060318	Lock CB46 (Coin Box)	1	LO

DOOR ASSEMBLY (continued)

Delivery Assembly

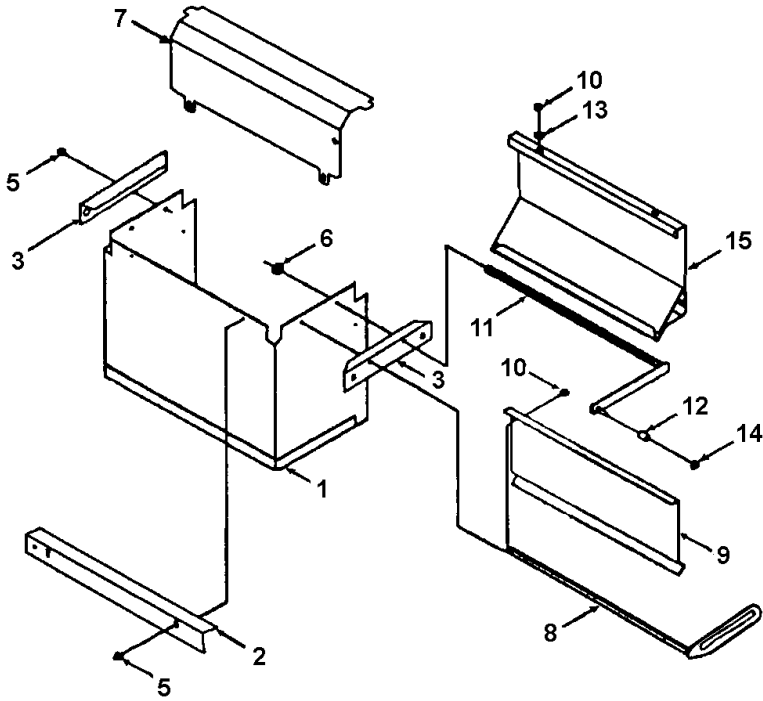

A10441

Delivery Assembly

ITEM	PART NO.	DESCRIPTION	QTY	CC
	1212040-006	Delivery Assembly – 3W, Outdoor		AS
	1212040-009	Delivery Assembly – 4W		AS
1	1212037-003	Delivery Weldment – 3W	1	WE
	1212037-004	Delivery Weldment – 4W	1	WE
2	4203436-003	Rear Delivery Deflector – 3W	1	ST
	4203436-004	Rear Delivery Deflector – 4W	1	ST
3	4203379	Delivery Mount	2	ST
5	4050423	8-18x3/8 Phil PH TY-AB	6	SC
6	4025263	Type 7 Nyliner-Snap in Plastic Bushing	4	BU
7	4203377-003	Delivery False Box – 3W	1	ST
	4203377-004	Delivery False Box – 4W	1	ST
8	1212039-003	Cam/Rod Weldment – 3W	1	WE
	1212039-004	Cam/Rod Weldment – 4W	1	WE
9	4203373-003	Del Anti-Cheat – 3W	1	ST
	4203373-004	Del Anti-Cheat – 4W	1	ST
10	4050239	8-32x1/2 Phil PH Type-T	6	SC
11	1212038-003	Follower Weldment – 3W	1	WE
	1212038-004	Follower Weldment – 4W	1	WE
12	4208947	Delivery Bushing	1	BU
13	8801011	#8 Flat Washer	6	WA
14	8801080	E-Ring 5/16	1	RR
15	1212041-003	Delivery Door Weldment – 3W	1	WE
	1212041-004	Delivery Door Weldment – 4W	1	WE

COMMON DOOR (CONTINUED)

Light Assembly

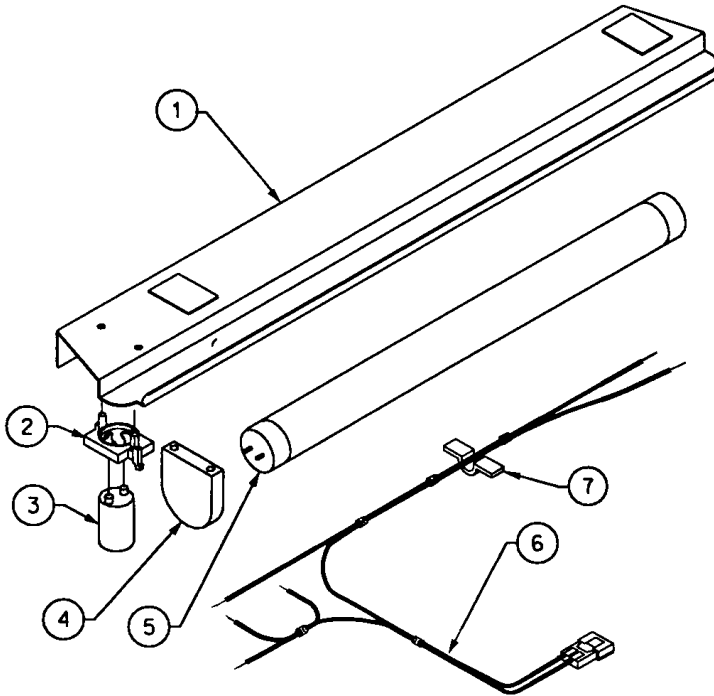

A10460

ITEM	PART NO.	DESCRIPTION	QTY	CC
	1214550-003	Light Assembly – 3W	1	AS
	1214550-004	Light Assembly – 4W	1	AS
1	1214531-003	Light Reflector Assy – 3W	1	WE
	1214531-004	Light Reflector Assy – 4W	1	WE
2	4208884	Starter Socket	1	EL
3	4033567	Starter – FS-2 – 3W	1	EL
	4033661	Starter – 4W	1	EL
4	4207171	Lamp Socket	2	EL
5	4033668	Lamp F14T8/Cw - 3W	1	LP
	4033549	Lamp F18T8/Cw - 4W	1	LP
6	4208807-003	Lamp Harness - 3W	1	HA
	4208807-004	Lamp Harness - 4W	1	HA
7	4060130	Press Clip-1/4"	1	CL

POWER PANEL ASSEMBLY

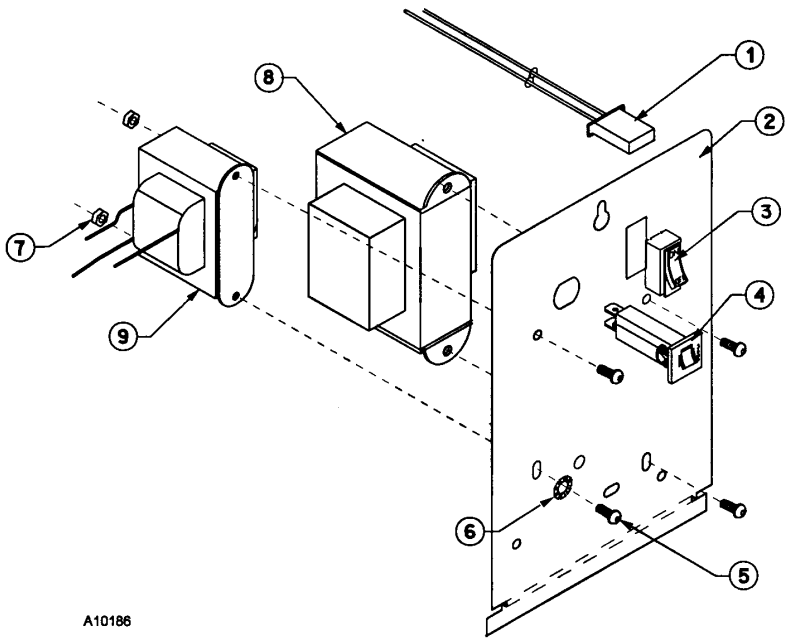

A10186

ITEM	PART NO.	DESCRIPTION	QTY	CC
	1214528-110	Power Assy/110v/3W/DOM/A		AS
	1214528-001	Power Assy/110v/4W/DOM/A		AS
1	4209153	Power Panel Harness	1	HA
2	4208695	Power Panel	1	ST
3	4202088	Switch – Rocker	1	SW
4	4203467-003	3 Amp Circuit Breaker	1	FU
5	4050240	8-32x3/8 Phil PH MS	5	SC
6	4050585	#8 External Tooth Lockwasher	5	WA
7	8800956	8-32 Hex Nut W/ ETW	5	NU
8	4206570-000	Transformer– 110 V	1	XF
9	4033609	Ballast SP2	1	XF
Not Shown	4033712	Cable Tie 7 3/8"	1	WT
	4033505	Closed End Splice Cap	2	EL

TRAY CONFIGURATIONS

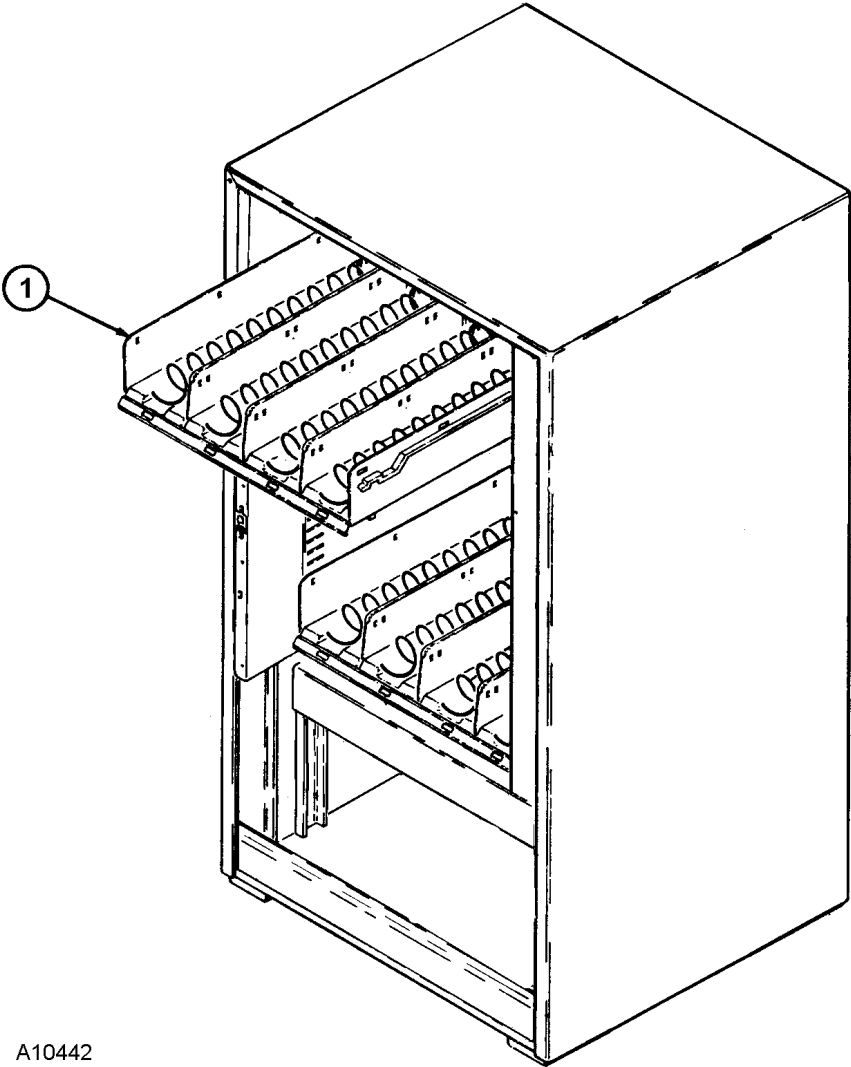

A10442

Tray Configurations

ITEM	PART NO.	DESCRIPTION	QTY
1	1214155-006	Tray Configuration 4632 (HR32)	
	1214644-002	Tray Assembly - 4-W - 15 Select	1
	1212048-403	Tray Assembly - 4-W - 18 Select	1
	1214644-003	Tray Assembly - 4-W - 10 Select Dual	4
	1214155-007	Tray Configuration 3523 (Horizon II, Outdoor Snack)	
	1212048-301	Tray Assembly - 3-W - 12 Select Snack	1
	1212048-302	Tray Assembly - 3-W - 4-12 Select Candy	2
	1212048-303	Tray Assembly - 3-W - 18 Select Candy	1
	1214644-004	Tray Assembly - 3-W - 4-18 Select Candy	1
	1214155-008	Tray Configuration (Trout)	
	1212048-324	Tray Assembly - 3-W - 15 Select	1
	1212048-326	Tray Assembly - 3-W - 30/18 Dual Select	1
	1212048-327	Tray Assembly - 3-W - 15/24/30 Select	1
	1212048-328	Tray Assembly - 3-W - 10 Select	3
	1214155-009	Tray Configuration (Bass)	
	1212048-324	Tray Assembly - 3-W - 15 Select	1
	1212048-325	Tray Assembly - 3-W - 15/24 Select	1
1212048-326	Tray Assembly - 3-W - 15/18 Dual Select	2	
1212048-329	Tray Assembly - 3-W - 30/18 Dual Select	2	
1214155-010	Tray Configuration (Detail)		
1212048-330	Tray Assembly - 3-W - 30 Select	1	
1212048-331	Tray Assembly - 3-W - 12/10/24 Select	1	
1212048-332	Tray Assembly - 3-W - 12/24 Select	1	
1212048-333	Tray Assembly - 3-W - 10/24 Select	1	
1212048-334	Tray Assembly - 3-W - 12 Select	1	

TRAY ASSEMBLY - 3- AND 4-WIDE

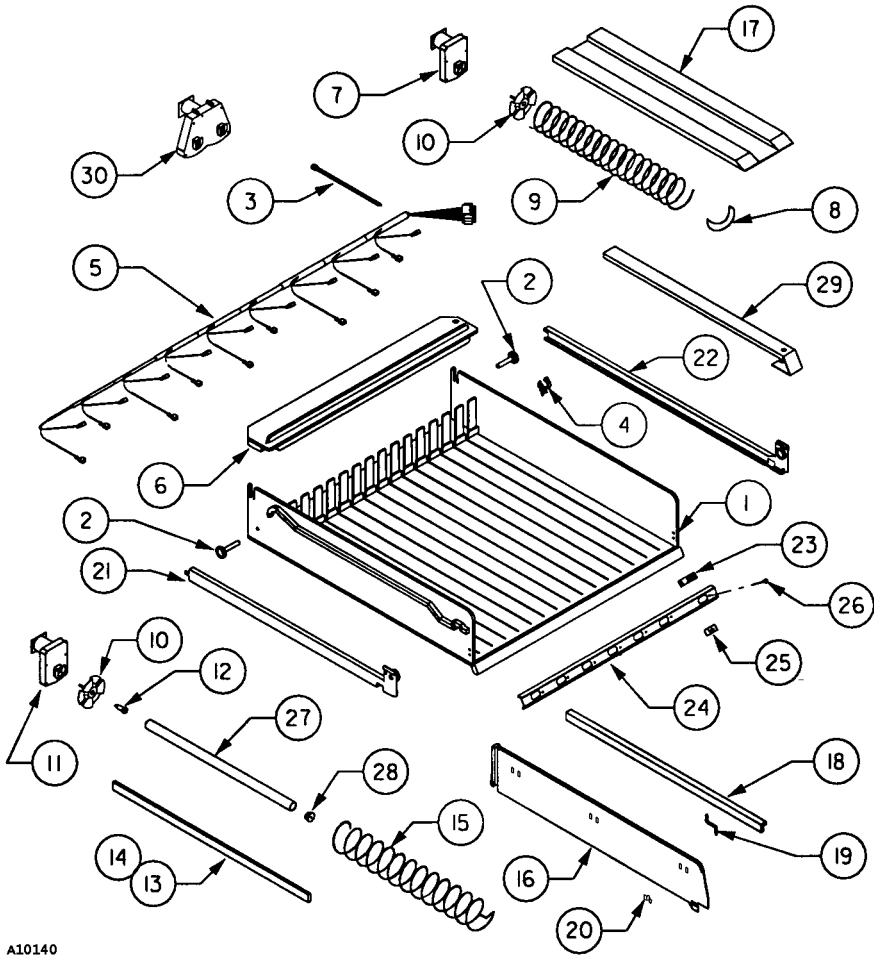

A10140

ITEM	PART NO.	DESCRIPTION	3-W	4-W	CC
1	4203275	Product Tray – 3-W	1		PL
	4203276	Product Tray – 4-W		1	PL
2	4060670-004	Roller	2	2	PL
3	4203509	Cable Tie	1	1	WT
4	4203468	Snap in Clip	1	1	CL
5	4203508-003	Tray Harness – 3-W	1		HA
	4203508-004	Tray Harness – 4-W		1	HA

Tray Assembly – 3- and 4-Wide

ITEM	PART NO.	DESCRIPTION	3-W	4-W	CC
6	4203277-003	Motor Cover – 3-W	1		PL
	4203277-004	Motor Cover – 4-W		1	PL
7	4034388	24 VDC Motor - 360 Degree/2-Wire	A/R	A/R	MO
8	4025748	Product Pusher/Ejector	A/R	A/R	PL
9	4200272-031	Auger - 10 Select - Candy	A/R	A/R	WF
	4205532-031	Auger - 10 Select - Candy –Right Hand	A/R	A/R	WF
	4200272-004	Auger - 12 Select - Candy	A/R	A/R	WF
	4200272-000	Auger - 15 Select - Candy	A/R	A/R	WF
	4200272-001	Auger - 18 Select - Candy	A/R	A/R	WF
	4205532-001	Auger - 18 Select - Candy –Right Hand	A/R	A/R	WF
	4200272-002	Auger - 24 Select - Candy	A/R	A/R	WF
	4200272-007	Auger - 10 Select - Snack	A/R	A/R	WF
	4200272-008	Auger - 12 Select - Snack	A/R	A/R	WF
	4200272-009	Auger - 15 Select - Snack	A/R	A/R	WF
	4200272-003	Auger - 30 Select - Candy	A/R	A/R	WF
	4202015	Auger Coupling	A/R	A/R	WF
11	4034388-001	24 VDC Motor - 180 Degree/2-Wire	A/R	A/R	MO
12	4200164-000	#8-32x1-1/4 Shoulder Screw	A/R	A/R	SC
13	4202624-001	Gum & Mint Spacer Strip	A/R	A/R	PL
14	4202013	1/32 x 3/8 Foam Tape, AP for item 13	A/R	A/R	TA
15	4202313-007	Auger - 40 Select - Gum & Mint	A/R	A/R	WF
16	4025797	Product Divider	A/R	A/R	PL
17	4200340	Helix Retainer	A/R	A/R	PL
18	8370660-5	Spacer	A/R	A/R	PL
19	8370998	Spacer Support	A/R	A/R	WF
20	4200281	Spring Clip	A/R	A/R	CL
21	1200321-002	Tray Rail - Left Side	1	1	RA
22	1200321-003	Tray Rail - Right Side	1	1	RA
23	4203341	Price Scroll – 5-95	A/R	A/R	LA
24	4203229-003	Label Holder – 3-W	1		PL
	4203229-004	Label Holder – 4-W		1	PL
25	4203707	Selection Identification Label	1	1	LA
26	4205749	Scroll Lock - Bumpers	A/R	A/R	RU
27	4202625-001	Gum & Mint Helix Tube	A/R	A/R	TU
28	4203103	End Cap	A/R	A/R	PL
29	4206251	Product Tray Spacer	A/R	A/R	ST
30	4205436	Dual Helix Motor	A/R	A/R	MO
Not Shown	4200164-000	#8-32x1-1/4 Shoulder Screw – AP for item No. 29	A/R	A/R	SC
	4050423	8-18x3/8 Phil PH Type-AB- AP for item No. 29	A/R	A/R	SC

CABINET ASSEMBLY

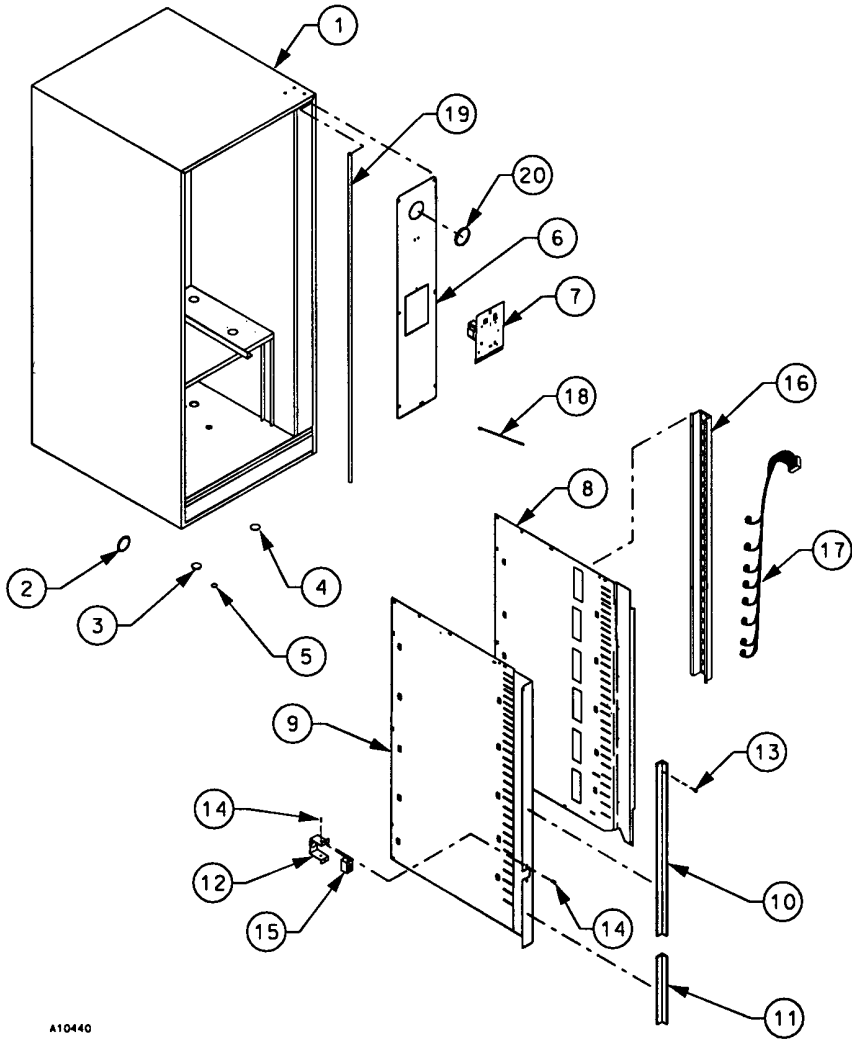

A10440

Cabinet Assembly

ITEM	PART NO.	DESCRIPTION	QTY	CC
	1214663-003	Cabinet Assembly – 3W		AS
	1214663	Cabinet Assembly – 4W		AS
	1214835	Cabinet Assembly – Outdoor		AS
1	1211432-009	Cabinet Weldment – 3W	1	WE
	1211432-011	Cabinet Weldment – 4W	1	WE
	1214842	Cabinet Weldment – Outdoor	1	WE
2	7250135-007	Hole Plug 2-1/4"	1	PL
3	7250135-000	Hole Plug 1 3/8"	2	PL
4	7250135-003	Hole Plug 3/4"	8	PL
5	7250135-001	Hole Plug 1/2"	3	PL
6	4208694	Control Panel	1	ST
7	1214528-xxx	Power Panel Assembly – See Page 13	1	ST
8	4203135-002	Right Side Panel	1	WE
9	1212109-002	Left Side Panel	1	ST
10	4203645-001	Anti-Cheat – Long	1	ST
11	4203645	Anti-Cheat – Short	1	ST
12	4203255	¼ Turn Nut Mount	1	ST
13	4050423	8-18x1/2 Phil HWH Teks	A/R	SC
14	8800638	10-16x3/8 Phil PH Type B	2	SC
15	4203634	Split Nut Assy	1	NU
16	4203143	Tray Receptacle	1	ST
17	4209022	Cabinet Harness	1	HA
18	4203509	Cable Tie	2	WT
19	4202256	Edge Guard	5 FT	GA
20	4206469	Edge Guard	.8 FT	GA
Not Shown	4050585	#8 External Tooth Lock Washer (Used on Grounding Wire)	1	WA

OUTDOOR SECURITY PACKAGE

Used With Outdoor Snack, Detail Centers,
and Sports Centers

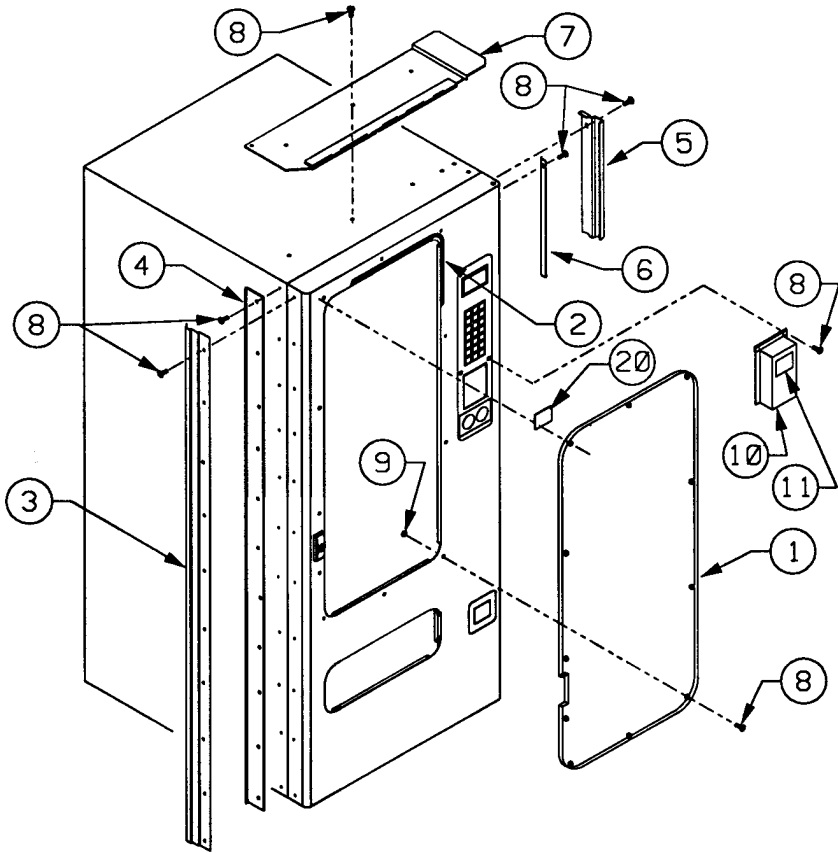

INSIDE
LOWER
REAR OF
CABINET

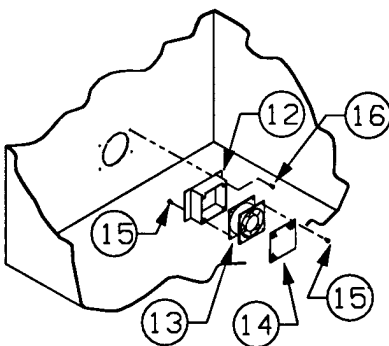

A10295

INSIDE
OF
DOOR

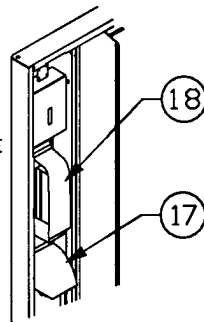

Outdoor Security Package

ITEM	PART NO.	DESCRIPTION	QTY	CC
1	4208095-003	Protective Window (3W)	1	PL
2	4209845	Protective Window Seal (3W)	1	GA
3	4208720-001	Anticheat – Left (Door)	1	ST
4	4208721-001	Anticheat – Left (Cabinet)	1	ST
5	4208722-001	Anticheat – Right (Cabinet)	1	ST
6	4208723-001	Anticheat – Right (Door)	1	ST
7	4209505	Top Security Plate (3W)	1	ST
8	4050393	1/4-20X3/4 Carriage Bolt (Plated)	50	SC
9	4050547	1/4-20 Twin Whiz Nut	50	NU
10	1214882	Weather Cover	1	WE
11	4209807	Label - Lift Cover Insert Money	1	LA
12	1214837	Fan Bracket	1	WE
13	4034344-000	Evaporator Fan (115V)	1	FA
14	4209715	Fan Cover	1	ST
15	8800638	10-16X3/8 Phil PH Type B	8	SC
16	4050202	8-18X1/2 PHIL HWH TEK	4	SC
17	4209698	Leak Guard Coinage	1	PL
18	4209700	Leak Guard Top	1	PL
19	4202777	1/2" Double Stick Tape, AP to item 18	5"	TA
20	4207281	Validator Label \$1/\$5 (option)	1	LA
Not Shown	4209710	Fan Harness	1	HA